

## MODEL "MQ" MINI-CODER

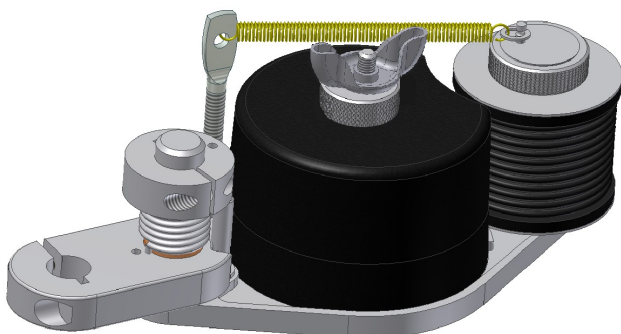

## PARTS LIST & OPERATING INSTRUCTIONS

### INSTALLATION

#### MOUNTING

The Mini-Coder comes equipped with a mounting bracket assembly which is sized to fit either a 9/16" diameter shaft of the conveyor side-mounting bracket accessory, part #1741-805. Whether using the mounting bracket accessory or a 9/16" diameter shaft it should be rigidly affixed to the parent equipment in such a manner that the coder can swing into a proper printing attitude without any interference. The length of the mounting shaft should be kept to a minimum to dampen vibrations.

R.H./L.H. (Factory assembled for L.H. Operation)

Fig #1 shows the proper mounting attitude for left hand or right hand operation. The only difference in the configuration is in the use of the left hand or right hand torsion spring (see parts list for appropriate part numbers). The torsion spring can be easily changed by employing the following steps:

- 1) Loosen the set screw on the clamp-tite collar.
- 2) Remove the collar from the mounting post.
- 3) Remove the torsion spring.
- 4) Repeat the first two steps in reverse order after installing the new spring.

NOTE: For Left-Hand Operation  
Use Spring No. 1741-003

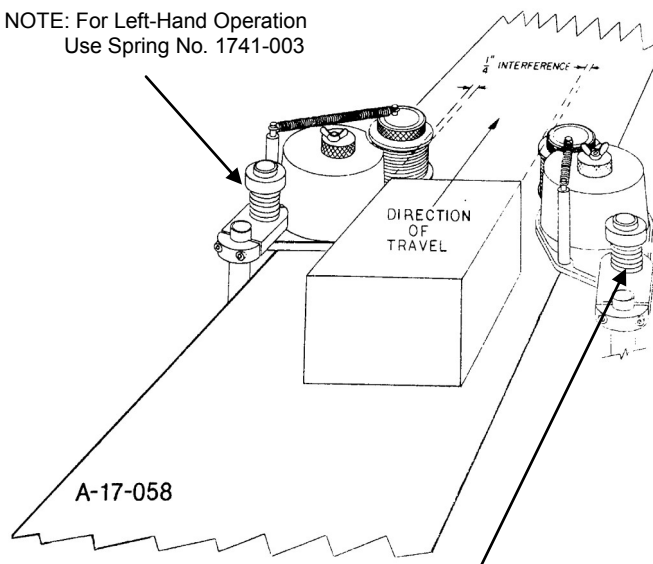

NOTE: For Right-Hand Operation  
Use Spring No. 1741-002

CORRECT MINI-CODER INSTALLATION, Figure 1

### SUPPORT

When printing on light objects, it may be necessary to provide a support rail on the side opposite the coder to maintain the 1/4" interference required to print properly

### OPERATION

#### PRINTING INTERFERENCE

Figure #1 shows the proper attitude of the coder required to maintain a 1/4" interference between the die wheel and the object being printed. The distance may be easily adjusted by loosening the mounting bracket set-screws, turning the coder to the desired angle and then retightening the mounting bracket.

#### PRINTING TENSION

The mini-coder is equipped with a torsion spring to provide the pressure required to insure proper printing and adequate engagement of the friction rings. The following steps should be employed to make adjustments to the printing tension:

- 1) With the cartridge cover and cartridge removed, loosen the clamp-tite collar set-screw (as illustrated in Fig. 2).
- 2) Turn the collar left or right as required.
- 3) Retighten the clamp-tite collar, and replace cartridge and cover.

#### INKING PRESSURE

The amount of ink distributed onto the type face is regulated by turning the eccentric Ink Adjustment Shaft (item #3). A wing-nut is provided to secure the shaft after proper inking is achieved. As the ink supply of a cartridge is depleted, it will be necessary to increase the inking pressure from time to time in small increments.

#### CARTRIDGE REPLACEMENT

To replace a cartridge, perform the following steps:

- 1) Remove the registration spring.
- 2) Unthread the wing nut and remove it.
- 3) Remove the cartridge cover and ink adjustment shaft by lifting straight up.
- 4) Remove the old cartridge.
- 5) Place a new cartridge in place.
- 6) Repeat steps 1 through 3 in reverse order.
- 7) Readjust inking pressure as described above.

## TYPE CHANGE

Die Wheel (P/N 1741-830) is equipped with rings which will accept standard Dilok Characters. Type changes are affected easily by loosening the knurled nut on the top of Die Wheel Ass'y (Item #8) and pulling the old characters from the die wheel. Now simply press the new characters in and tighten the knurled nut.

The Die Wheel can be easily removed for type changes by pulling straight up, after removing the registration spring. However, a retaining screw is provided (Figure 2) to prevent removal, when so desired.

## IMPRINT REGISTRATION

If some thought is given to placement of the characters on the Die Wheel, proper registration of the print can easily be achieved. For adjustment simply loosen the knurled nut, turn the rings until the print is brought into proper registry, and then tighten the knurled nut. Should the Die Wheel Friction Rings roll off of the object being imprinted when the Registration Spring Anchor Pin on item #8 is exactly 180° from its normal resting position, the Die Wheel may not come back to its "at rest" position. This problem may be corrected by making a slight change in the attitude of the coder.

An Extra Light Weight Spring (Item #7) is provided for use when coding small or light items. For ease of identification this spring has been color-coded red and has a stock number of 1741-834.

## MAINTENANCE

### SERVICING

The mini-coder may be serviced without interfering with product flow by loosening the screws in the mounting bracket assembly and pivoting the coder out of the product flow. To return the coder to service, swing it back to its original position and secure the screws.

### CLEANING

Periodic cleaning of the mini-coder and type are necessary to insure proper function and sharp printing. Hydrocarbon solvents should not be used on the rubber type. Rol-It-On Ink Conditioner is recommended for cleaning purposes.

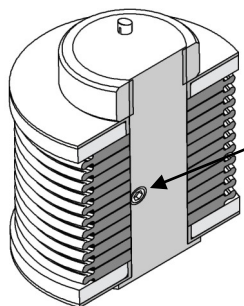

NOTE: With Set-Screw in this position the Die Wheel cannot be removed. Remove Set-Screw to have a quick-change Die Wheel.

DIE WHEEL ASSEMBLY 1741-830, Figure 2

## TROUBLESHOOTING

Some of the problems which may be encountered in using the mini-coder are listed below along with the most common causes & solutions.

### PARTIAL IMPRINTS

If the mini-coder gives spotty or incomplete impressions, the following things could be responsible:

- 1) Insufficient inking pressure—rotate the ink adjustment shaft to obtain adequate contact between the cartridge and type face.
- 2) Insufficient printing tension—loosen the clamp-tite collar, rotate to remedy the problem, and retighten the collar.
- 3) Work or improperly seated type—replace if necessary.
- 4) Depleted cartridge—replace or re-ink as required.
- 5) Poorly mounted coder—The die wheel must be parallel to the surface being imprinted and have the proper 1/4" interference to operate properly. Rigid mounting is also necessary and all set-screws must be tight to prevent slipping.

### HEAVY IMPRESSIONS

An overabundance of ink is usually caused by one of the following:

- 1) Over-inked cartridge—replace the cartridge and allow it to drain before reinstalling.
- 2) Excessive inking pressure—rotate the ink adjustment shaft until an adequate level of inking is maintained.

### OUTLINE IMPRESSIONS OR "GHOSTING"

Outline impressions are usually caused by one or more of the following problems:

- 1) Mixed type—do not use old and new type together or mix styles or brands.
- 2) Excessive printing tension—Loosen the clamp-tite collar rotate to relieve pressure, and retighten the clamp.
- 3) Excessive inking pressure—rotate the ink adjustment shaft until the problem is eliminated.

### ERRATIC REGISTRATION

If the registration of the impression wanders, one or more of the following problems may exist:

- 1) Improper attitude—move the coder slightly into or slightly out of the product flow. This will allow the spring to return the Die Wheel to its "at-rest" position.
- 2) Inadequate Printing Pressure—increase the pressure by adjusting the clamp-tite collar as required.
- 3) Broken or missing registration spring—replace or install a new spring.

## MINI CODER PARTS LIST

REF NO.	STOCK NO.	DESCRIPTION	REQ'D
1	1741-100	Cartridge, XLM Uninked	1
	1741-101	Cartridge, XLM Black	
	1741-111	Cartridge, DiDark Black	
	1741-120	Cartridge, Foam Uninked	
2	1741-803	Mounting Bracket Ass'y (with screws)	1
3	1741-833	Spring & Washer Assembly	1
	1741-834	Spring & Washer Assembly, Light Weight (red color coded)	
4	1741-830	Die Wheel Assembly, MQ	1
5	1741-835	Base Assembly, Mini Coder	1

